

Grizzly

Industrial, Inc.®

MODEL T10010 WET GRINDER

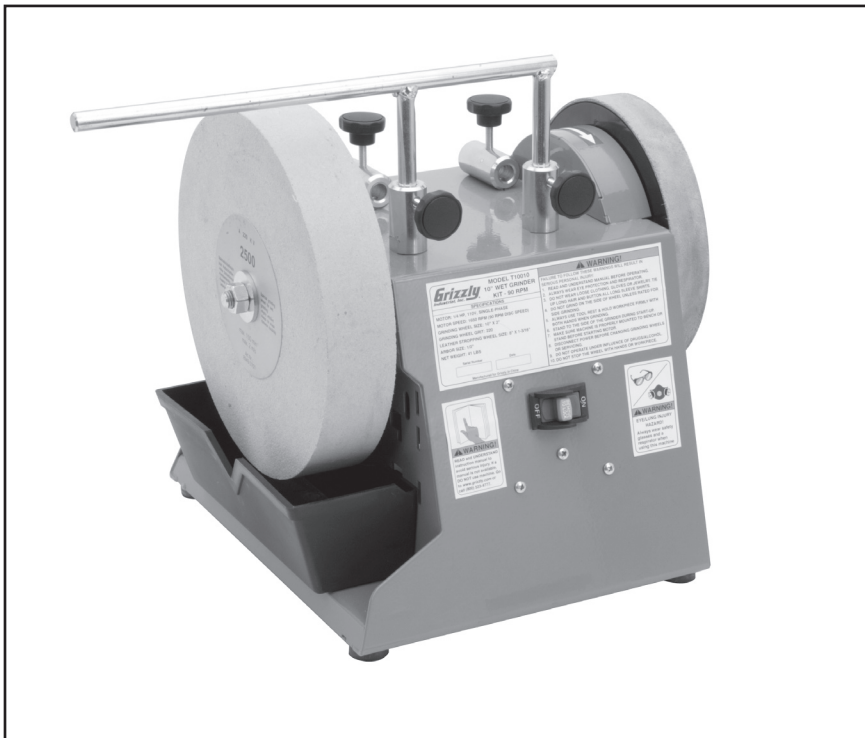

COPYRIGHT © NOVEMBER, 2007 BY GRIZZLY INDUSTRIAL, INC.
**WARNING: NO PORTION OF THIS MANUAL MAY BE REPRODUCED IN ANY SHAPE
OR FORM WITHOUT THE WRITTEN APPROVAL OF GRIZZLY INDUSTRIAL, INC.**
#JB9991 PRINTED IN CHINA

 **WARNING!**

This manual provides critical safety instructions on the proper setup, operation, maintenance and service of this machine/equipment.

Failure to read, understand and follow the instructions given in this manual may result in serious personal injury, including amputation, electrocution or death.

The owner of this machine/equipment is solely responsible for its safe use. This responsibility includes but is not limited to proper installation in a safe environment, personnel training and usage authorization, proper inspection and maintenance, manual availability and comprehension, application of safety devices, blade/cutter integrity, and the usage of personal protective equipment.

The manufacturer will not be held liable for injury or property damage from negligence, improper training, machine modifications or misuse.

 **WARNING!**

Some dust created by power sanding, sawing, grinding, drilling, and other construction activities contains chemicals known to the State of California to cause cancer, birth defects or other reproductive harm. Some examples of these chemicals are:

- **Lead from lead-based paints.**
- **Crystalline silica from bricks, cement and other masonry products.**
- **Arsenic and chromium from chemically-treated lumber.**

Your risk from these exposures varies, depending on how often you do this type of work. To reduce your exposure to these chemicals: Work in a well ventilated area, and work with approved safety equipment, such as those dust masks that are specially designed to filter out microscopic particles.

SAFETY

WARNING

For Your Own Safety Read Instruction Manual Before Operating This Equipment

The purpose of safety symbols is to attract your attention to possible hazardous conditions. This manual uses a series of symbols and signal words which are intended to convey the level of importance of the safety messages. The progression of symbols is described below. Remember that safety messages by themselves do not eliminate danger and are not a substitute for proper accident prevention measures.

DANGER

Indicates an imminently hazardous situation which, if not avoided, WILL result in death or serious injury.

WARNING

Indicates a potentially hazardous situation which, if not avoided, COULD result in death or serious injury.

CAUTION

Indicates a potentially hazardous situation which, if not avoided, MAY result in minor or moderate injury. It may also be used to alert against unsafe practices.

NOTICE

This symbol is used to alert the user to useful information about proper operation of the equipment.

WARNING

Safety Instructions for Machinery

- 1. READ THROUGH THE ENTIRE MANUAL BEFORE STARTING MACHINERY.** Machinery presents serious injury hazards to untrained users.
- 2. ALWAYS USE ANSI APPROVED SAFETY GLASSES WHEN OPERATING MACHINERY.** Everyday eyeglasses only have impact resistant lenses, they are NOT safety glasses.
- 3. ALWAYS WEAR A NIOSH APPROVED RESPIRATOR WHEN OPERATING MACHINERY THAT PRODUCES DUST.** Wood dust is a carcinogen and can cause cancer and severe respiratory illnesses.
- 4. ALWAYS USE HEARING PROTECTION WHEN OPERATING MACHINERY.** Machinery noise can cause permanent hearing damage.
- 5. WEAR PROPER APPAREL.** DO NOT wear loose clothing, gloves, neckties, rings, or jewelry which may get caught in moving parts. Wear protective hair covering to contain long hair and wear non-slip footwear.
- 6. NEVER OPERATE MACHINERY WHEN TIRED, OR UNDER THE INFLUENCE OF DRUGS OR ALCOHOL.** Be mentally alert at all times when running machinery.

7. **ONLY ALLOW TRAINED AND PROPERLY SUPERVISED PERSONNEL TO OPERATE MACHINERY.** Make sure operation instructions are safe and clearly understood.
8. **KEEP CHILDREN AND VISITORS AWAY.** Keep all children and visitors a safe distance from the work area.
9. **MAKE WORKSHOP CHILD PROOF.** Use padlocks, master switches, and remove switch keys.
10. **NEVER LEAVE WHEN MACHINE IS RUNNING.** Turn power **OFF** and allow all moving parts to come to a complete stop before leaving machine unattended.
11. **DO NOT USE IN DANGEROUS ENVIRONMENTS.** DO NOT use machinery in damp, wet locations, or where any flammable or noxious fumes may exist.
12. **KEEP WORK AREA CLEAN AND WELL LIT.** Clutter and dark shadows may cause accidents.
13. **USE A GROUNDED EXTENSION CORD RATED FOR THE MACHINE AMPERAGE.** Undersized cords overheat and lose power. Replace extension cords if they become damaged. DO NOT use extension cords for 220V machinery.
14. **ALWAYS DISCONNECT FROM POWER SOURCE BEFORE SERVICING MACHINERY.** Make sure switch is in OFF position before reconnecting.
15. **MAINTAIN MACHINERY WITH CARE.** Keep blades sharp and clean for best and safest performance. Follow instructions for lubricating and changing accessories.
16. **MAKE SURE GUARDS ARE IN PLACE AND WORK CORRECTLY BEFORE USING MACHINERY.**
17. **REMOVE ADJUSTING KEYS AND WRENCHES.** Make a habit of checking for keys and adjusting wrenches before turning machinery **ON**.
18. **CHECK FOR DAMAGED PARTS BEFORE USING MACHINERY.** Check for binding and alignment of parts, broken parts, part mounting, loose bolts, and any other conditions that may affect machine operation. Repair or replace damaged parts.
19. **USE RECOMMENDED ACCESSORIES.** Refer to the instruction manual for recommended accessories. The use of improper accessories may cause risk of injury.
20. **DO NOT FORCE MACHINERY.** Work at the speed for which the machine or accessory was designed.
21. **SECURE WORKPIECE.** Use clamps or a vise to hold the workpiece when practical. A secured workpiece protects your hands and frees both hands to operate the machine.
22. **DO NOT OVERREACH.** Keep proper footing and balance at all times.
23. **MANY MACHINES WILL EJECT THE WORKPIECE TOWARD THE OPERATOR.** Know and avoid conditions that cause the workpiece to "kickback."
24. **ALWAYS LOCK MOBILE BASES (IF USED) BEFORE OPERATING MACHINERY.**
25. **BE AWARE THAT CERTAIN WOODS MAY CAUSE AN ALLERGIC REACTION** in people and animals, especially when exposed to fine dust. Make sure you know what type of wood dust you will be exposed to and always wear an approved respirator.

WARNING

Additional Safety Instructions for Grinders

- 1. EYE PROTECTION.** Grinding causes small particles to become airborne at a high rate of speed. ALWAYS wear safety glasses when using this machine.
- 2. WHEEL SPEED RATING.** Wheels operated at a faster speed than rated for may break or fly apart. Before mounting a new wheel, be sure the wheel RPM rating is equal to or higher than the speed of the grinder.
- 4. WHEEL FLANGES.** Only use the flanges included with the grinder when mounting wheels. Other flanges may not properly secure the wheel and cause an accident.
- 5. RING TEST.** Perform a “ring test” on grinding wheels before installation to ensure that they are safe to use. A wheel that does not pass the ring test may break or fly apart during operation.
- 6. STARTING GRINDER.** If a wheel IS damaged, it will usually fly apart shortly after start-up. To protect yourself, always stand to the side of the grinder when turning it **ON**, allow it to gain full speed and wait for at least 1 minute before standing in front of it.
- 7. LUNG PROTECTION.** Grinding produces hazardous dust, which may cause long-term respiratory problems if breathed. Always wear a NIOSH approved dust mask or respirator when grinding.
- 8. SIDE GRINDING.** Grinding on the side of wheels can cause them to break and fly apart—unless the wheel is rated for side grinding.
- 9. HAND/WHEEL CONTACT.** Grinding wheels have the capability of removing a lot of skin fast. Keep a firm grip on the workpiece and position your hands at a safe distance away when grinding. Avoid wearing gloves, as they may get caught in the grinding wheel and cause even more serious entanglement injuries.
- 10. TOOL REST POSITION.** If the tool rest is too far away from the wheel, the workpiece may be pulled down, causing loss of control and pulling your hand into the grinding wheel. Keep the tool rest within 1/8" from the wheel when operating.

INTRODUCTION

Foreword

We are proud to offer the Grizzly Model T10010 Wet Grinder. This model is part of a growing Grizzly family of fine power tools. When used according to the guidelines set forth in this manual, you can expect years of trouble-free, enjoyable operation and proof of Grizzly's commitment to customer satisfaction.

It is our pleasure to provide this manual with the Model T10010. It was written to encourage safety considerations and guide you through general operating procedures and maintenance.

The specifications, details, and photographs in this manual represent the Model T10010 as supplied when the manual was prepared. However, owing to Grizzly's policy of continuous improvement, changes may be made at any time with no obligation on the part of Grizzly.

Contact Info

Most importantly, we stand behind our tools. If you have any service questions or parts requests, please call or write us at the location listed below.

Grizzly Industrial, Inc.
1203 Lycoming Mall Circle
Muncy, PA 17756

Phone: (570) 546-9663

Fax: (800) 438-5901

E-Mail: techsupport@grizzly.com

Web Site: <http://www.grizzly.com>

If you have any comments regarding this manual, please contact us:

Grizzly Industrial, Inc.
C/O Technical Documentation Manager
P.O. Box 2069
Bellingham, WA 98227-2069
Email: manuals@grizzly.com

⚠ WARNING

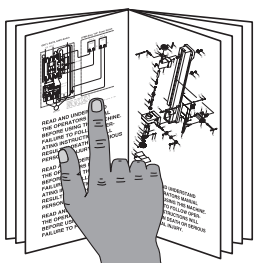

Read the manual before operation. Become familiar with this grinder, its safety instructions, and its operation before beginning any work. Serious personal injury may result if safety or operational information is not understood or followed.



MACHINE DATA SHEET

Customer Service #: (570) 546-9663 • To Order Call: (800) 523-4777 • Fax #: (800) 438-5901

MODEL T10010 WET GRINDER

Overall Dimensions:

Height.....	13"
Width.....	17"
Depth.....	13"
Net Weight.....	41 lbs.
Footprint.....	13" x 10 ³ / ₄ "

Main Specifications:

Arbor Diameter.....	1/2"
Grinding Wheel Grit.....	220
Grinding Wheel Size.....	10" x 2"
Grinding Wheel Material.....	Aluminum Oxide
Stropping Wheel Size.....	8" x 1 ³ / ₁₆ "
Stropping Wheel Material.....	ABS/Leather
Wheel Speed.....	90 RPM

Motor:

Type.....	TEFC Capacitor Start Induction
Horsepower.....	1/4 HP
Phase/Voltage.....	Single/110V
Amps.....	3A
Cycle/RPM.....	60Hz/1725 RPM

Features:

- Universal Tool Support
- Paddle Switch w/ Disabling Key
- Water Reservoir
- Included 220 Grit Aluminum Oxide Grinding Wheel
- Included Leather Stropping Wheel
- Included Stropping Paste
- Included Angle Guide

CIRCUIT REQUIREMENTS

110V Operation

Amperage Draw

The Model T10010 motor draws the following amps under maximum load:

Motor Draw.....3 Amps

Minimum Circuit Requirement

We recommend connecting your machine to a dedicated and grounded circuit that is rated for the amperage given below. Never replace a circuit breaker on an existing circuit with one of higher amperage without consulting a qualified electrician to ensure compliance with wiring codes. **If you are unsure about the wiring codes in your area or you plan to connect your machine to a shared circuit, consult a qualified electrician.**

110V Circuit.....15 Amps

Plug/Receptacle Type

Included Plug Type.....NEMA 5-15

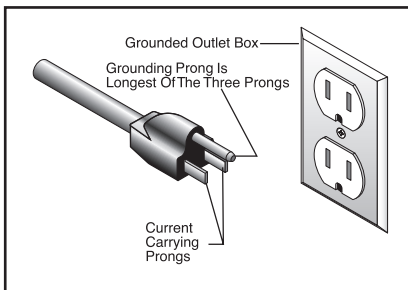

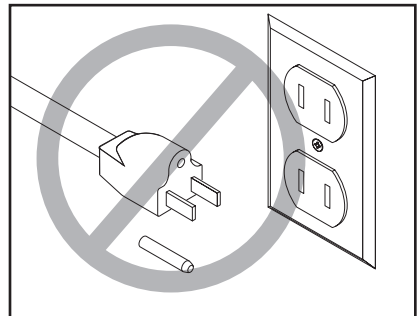

Figure 1. Plug & receptacle type.

⚠ WARNING	
	Electrocution or fire could result if this machine is not grounded correctly or if your electrical configuration does not comply with local and state codes. Ensure compliance by checking with a qualified electrician!



⚠ CAUTION	
This machine must have a ground prong in the plug to help ensure that it is grounded. DO NOT remove ground prong from plug to fit into a two-pronged outlet! If the plug will not fit the outlet, have the proper outlet installed by a qualified electrician.	

Extension Cords

We do not recommend the use of extension cords, but if you find it absolutely necessary:

- Use at least a 14 gauge cord that does not exceed 50 feet in length!
- The extension cord must also contain a ground wire and plug pin.
- A qualified electrician **MUST** size cords over 50 feet long to prevent motor damage.

SECTION 3: SETUP

Unpacking

The Model T10010 was carefully packed when it left our warehouse. If you discover any parts are damaged after you have signed for delivery, *please immediately call Customer Service at (570) 546-9663 for advice.* Save the containers and all packing materials for possible inspection by the carrier or its agent. *Otherwise, filing a freight claim can be difficult.* When you are completely satisfied with the condition of your shipment, you should inventory the contents.

Inventory

Model T10010 Inventory (Figure 2)

- A. T10010 Wet Grinder 1
- B. Angle Measurer..... 1
- C. Polishing/Honing Paste..... 1

!WARNING

The Model T10010 Wet Grinder weighs 41 pounds. **DO NOT over-exert yourself while unpacking or moving the grinder.** Use proper lifting techniques to prevent injury.

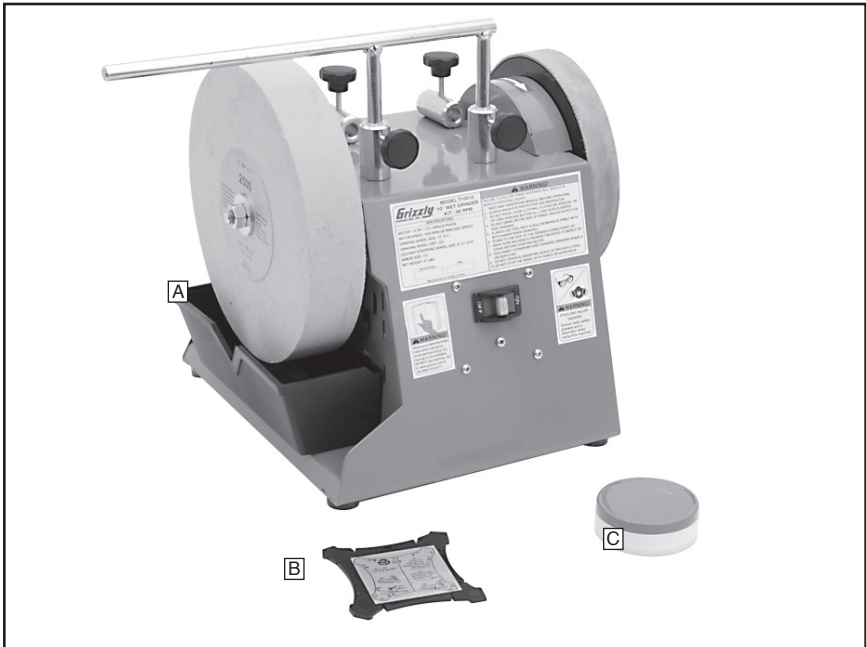

Figure 2. Model T10010 inventory.

Site Considerations

Bench Load

Refer to the **Specifications on Page 6** for the weight and size specifications of your machine. Some workbenches may require additional reinforcement to support both the machine and the workpiece.

Placement Location

See **Figure 3** for the minimum working clearances. Remember that the Model T10010 Wet Grinder has no specific front or back side and must be repositioned depending on the desired grinding/sharpening/honing action.

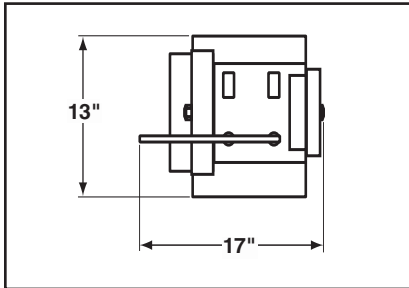

Figure 3. Minimum working clearances.

	<p>⚠ CAUTION</p> <p>Children and visitors may be seriously injured if unsupervised. Lock all entrances to the shop when you are away. DO NOT allow unsupervised children or visitors in your shop at any time!</p>
--	---

Wheel Inspection

Do not assume that a wheel is in sound condition just because it is new—often damage can occur in shipping, with age, or with prolonged exposure to moisture. Inspect every wheel for damage.

First, do a **Visual Inspection**. Look for any cracks, chips, nicks or dents in the surface of the wheel. If you see any of these, DO NOT use the wheel.

Second, do a **Ring Test**. This test will give you an indication of any internal damage that may not be obvious during a visual inspection.

To perform a Ring Test:

1. Make sure the wheel that you test is clean and dry; otherwise, you may get false results.
2. If size permits, balance the wheel with your finger in the hole. If this is not possible, hang the wheel in the air with a piece of cord or string looped through the hole in the center.
3. At the spots shown in **Figure 4**, gently tap the wheel with a light non-metallic device such as the handle of a screwdriver or a wooden mallet.

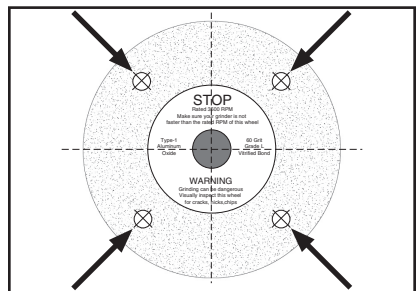

Figure 4. Tapping locations when performing a ring test.

- An undamaged wheel will emit a clear metallic ring or “ping” sound in each of these spots. A damaged wheel will respond with a dull thud that has no clear tone.
- If you determine from the ring test that the wheel is damaged, **DO NOT** use it!

Finally, check that the **grinding surface is square**. Lower the universal support to $\frac{1}{16}$ "- $\frac{1}{8}$ " above the grinding wheel. Using the universal support as a visual guide, check that the entire surface of the grinding wheel is consistent and parallel to the universal support, as shown in **Figure 5**. (If this is not the case, see **Wheel Dressing** on **Page 16**.)

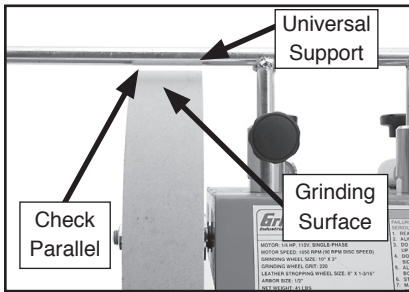

Figure 5. Parallel check.

Test Run

Once your Model T10010 is positioned, test run the machine to make sure it runs properly.

If, during the test run, you cannot easily locate the source of an unusual noise or vibration, stop using the machine immediately, then review the **Troubleshooting** on **Page 20**.

If you still cannot remedy a problem, contact our Tech Support at (570) 546-9663 for assistance.

To test run the machine:

- Make sure you have read the safety instructions at the beginning of the manual and that the grinder is setup properly.
- Make sure all tools and objects used during set up are cleared away from the grinder.
- Make sure the switch is in the OFF position.
- Connect the grinder to the power source.
- Flip the switch to the right to turn the grinder **ON**. Make sure that your hand stays poised over the switch in case you need to quickly turn the machine **OFF**.
- Listen to and watch for abnormal noises or actions. Under normal conditions, the grinder will make a humming noise, with only minor vibration.
 - Strange or unusual noises should be investigated and corrected before operating the machine further. Always disconnect the machine from power before investigating or correcting potential problems.
- Turn the grinder **OFF**.
- Remove the switch disabling key and attempt to turn the machine **ON**.
 - If the grinder does not start, the switch disabling feature is working.
 - If the grinder starts, stop it. The switch disabling feature is not working. This safety feature must work properly before proceeding. Call Tech Support for help.

OPERATIONS

Operation Safety

⚠️ WARNING

Damage to your eyes and lungs could result from using this machine without proper protective gear. Always wear safety glasses/faceshield and a dustmask/respirator when operating this machine.

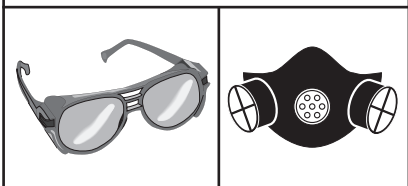

⚠️ WARNING

Loose hair and clothing could get caught in machinery and cause serious personal injury. Keep loose clothing and long hair away from moving machinery.

NOTICE

If you have never used this type of machine or equipment before, WE STRONGLY RECOMMEND that you read books, trade magazines, or get formal training before beginning any projects. Regardless of the content in this section, Grizzly Industrial will not be held liable for accidents caused by lack of training.

⚠️ CAUTION

Although the Model T10010 Wet Grinder wheels are designed specifically for slow rotation, there is still the possibility that blades and tools being sharpened on either wheel could be dislodged from your grasp. Be sure that satisfactory space is allocated between the grinder and areas where others are working. Always wear safety glasses and keep the universal support in the proper position when grinding or sharpening.

Grinding Tips

The grinder is a safe tool when used properly. In addition to the safety instructions in this manual, the most important safety consideration is to use common sense at all times. What may be okay in one situation, may not be safe in another.

Here are some tips to keep in mind while grinding:

- Always be sure the grinding wheel is wet before grinding by having the reservoir filled and in the proper location.
- Wear the proper protective clothing. Safety glasses/face shield and a dust mask should be worn at all times.
- Grasp the workpiece firmly and properly support it on the universal support/tool rest during grinding. Maintain even pressure and control of the workpiece when grinding.
- Concentrate on the task at hand. STOP grinding if other people are distracting you or your mind is on something else.

Positioning the Universal Support

The Model T10010 Wet Grinder is equipped with a universal support that serves as a tool rest and as an attachment point for job-specific accessories. It can be attached in two positions, allowing for grinding *with* or *against* the rotation direction of the grinding wheel. The tightening knobs on each attachment point allow the universal support to be adjusted and locked in position, depending on the specific task required.

To work against the rotation of the grinding wheel:

1. Position the machine with the ON/OFF switch facing you.
2. Attach the universal support in the vertical mounts as shown in **Figure 6**. Be sure it is securely positioned and will not move during grinding.
3. Rest your workpiece on the universal support with the sharpened edge pointing away from you. Grind your workpiece in the indicated grinding area.

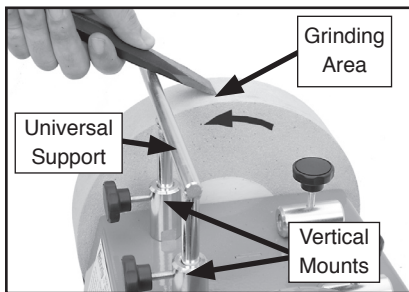

Figure 6. Vertical mount.

Working against the rotation removes large amounts of materials quickly but does not yield precise results. Use this method for coarse tools such as axes.

To work with the rotation of the grinding wheel:

1. Position the machine with the ON/OFF switch facing away from you.
2. Attach the universal support in the horizontal mounts as shown in **Figure 7**. Be sure it is securely positioned and will not move during grinding.
3. Rest your workpiece on the universal support with the sharpened edge pointing away from you. Grind your workpiece in the indicated grinding area.

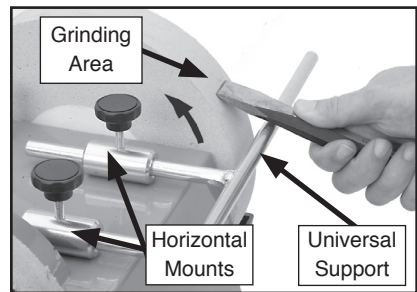

Figure 7. Horizontal mount.

The universal support should never be placed in the vertical mounts while using the leather stropping wheel. Working against the direction of rotation in this case will cause severe damage to the leather wheel.

Working with the rotation yields much more precise results and removes less material. Use this method for finer tools, such as knives or carving tools.

CAUTION

Do not make adjustments while the machine is running. Disconnect the grinder from power before attempting to make adjustments to the universal support, water reservoir, changing wheels or the angle guide.

Water Reservoir

The Model T10010 Wet Grinder is designed for wet grinding and should never be used without water.

Before filling the water reservoir, identify the high and low reservoir mounting slots. These slots allow the reservoir to be raised during grinding and lowered when not in use.

The mounting tabs on the reservoir serve as hooks to attach to the reservoir mounting slots (**Figure 8**).

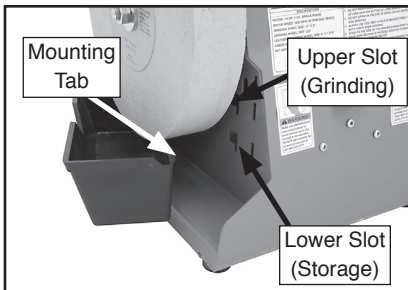

Figure 8. Reservoir mounting positions.

NOTICE

DO NOT attempt to use the grinding wheel without filling the reservoir with water. Overheating caused by lack of lubrication could damage the grinding wheel, as well as the tool or blade you are grinding. Ensure that the reservoir is filled with clean water. Sediment-filled water can clog the wheel and lessen the effectiveness of the grinder.

To fill and position the reservoir:

1. Make sure the grinder is disconnected from power and that the grinding wheel is not rotating.
2. Remove reservoir and fill with water to just below the V-shaped notch.
3. Attach the reservoir to the grinder.
 - If the grinder is going to be used immediately, position the reservoir in the grinding position by attaching it in the upper slot (**Figure 9**).
 - If the grinder is not going to be used immediately, position the reservoir in the storage position by attaching it in the lower slot (**Figure 10**).

Note: *Placing the reservoir in the storage position prevents damage to the wheel and potential hazards from being stored in water.*



Figure 9. Grinding position.



Figure 10. Storage position.

⚠ CAUTION

DO NOT allow the grinding wheel to stay immersed in water for long periods of time without running. The water can cause the wheel to become waterlogged and unbalanced and may cause sections of the wheel to break off when the grinder is started. Always empty or lower the reservoir to the storage position when the grinder will not be used.

Here are some tips for using your wet grinder water reservoir:

- Check the water level before every use and be sure the wheel is wet before you begin grinding. DO NOT use the grinder without water.
- Leaving the grinding wheel stored in water will cause damage to the wheel and create potential hazards because the wheel will become unbalanced. Once any grinding process is complete, return the reservoir to the storage position to prevent prolonged water exposure to the wheel.
- Empty, rinse, and refill the reservoir regularly. This prevents metal and stone from accumulating in the reservoir.
- Place a magnet in the reservoir to catch and collect metal filings. This will help prevent excessive metal accumulation on the grinding wheel.

Angle Guide

The Model T10010 Wet Grinder comes with an angle guide to help identify and maintain the cutting angle on a variety of tools.

To use the angle guide:

1. Locate the eight measuring notches on the angle finder (**Figure 11**).

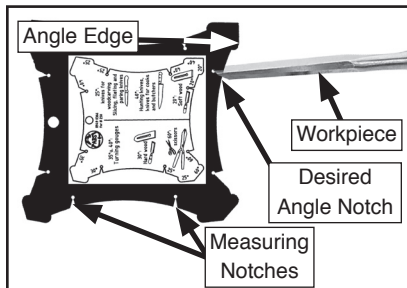

Figure 11. Measuring notches.

2. Find the angle notch that best fits the tool you wish to grind by placing the sharpened edge of the workpiece into each notch.
3. Place the angle guide on the wheel with the desired angle notch (found in **Step 2**) against the wheel and adjacent to the universal support (**Figure 12**).

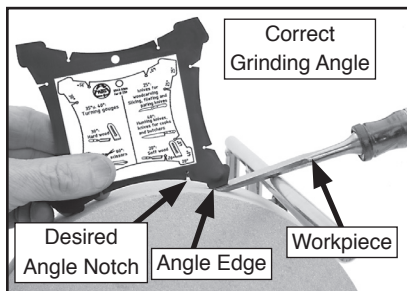

Figure 12. Angle guide usage.

4. Adjust the positioning of the tool and the universal support height as necessary so that the sharpened edge of the tool is flat against both the grinding wheel and the angle edge on the angle guide as shown in **Figure 12**. For precision grinding attachments, see **Accessories on Page 17**.

Wheel Dressing

Depending on the type of grinding you do, the grinding wheel may require periodic dressing.

A variety of dressing tools are available (see **Accessories, Page 17**) and can be used to restore the abrasive quality of the wheel surface and bring the wheel edge back to a square form.

Refer to the instructions that accompany your dressing accessory for complete details on how to properly dress a wheel.

Sharpening

The leather stropping wheel on the Model T10010 and the included abrasive stropping paste can be used to obtain a razor sharp edge on many tools. Before use, the stropping wheel must be properly prepared.

To prepare the stropping wheel:

1. DISCONNECT GRINDER FROM POWER.
2. Make sure the wet grinder is disconnected from power and that the stropping wheel is not rotating.
3. Evenly apply a light machine oil to the leather wheel. Use enough oil to provide a thorough coating, but not so much as to saturate the leather and result in dripping.
4. Apply a thin coat of abrasive honing paste to the leather wheel using a wooden spreader or similar device. Distribute the paste evenly by hand-turning the wheel while spreading.
5. Turn the machine on and continue to distribute the paste, still using the wooden spreader. Move the spreader lightly in a circular motion across the wheel.
6. Once the paste is evenly distributed, begin sharpening.

These preparations will be sufficient for sharpening five to ten tools. If you notice a drop in sharpening performance or have sharpened more than ten tools, repeat **Steps 1-6**.

SECTION 5: ACCESSORIES

T10023—Accessory Kit #1 Includes fixtures for sharpening small knives, large knives, scissors and axes.

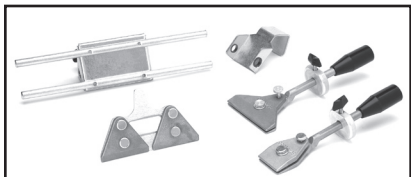

Figure 14. Model T10023

T10024—Accessory Kit #2 Includes a stone dresser and fixtures for sharpening scrapers, screwdrivers and hollow chisels.



Figure 15. Model T10024.

T10025—Sharpening Jig. Jig for sharpening 16" planer blades sharpens all planer and jointer blades up to 16" long.

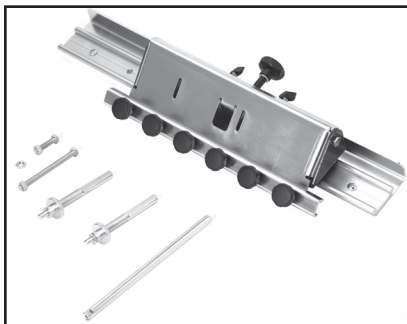

Figure 16. Model T10025.

G7120—Heavy Duty Grinder Stand

This is one of the most stable bench grinder stands on the market. Once you have one, you'll wonder how you ever got along without it. 32½" high. Will require the installation of a tabletop (not included) for use with the Model T10010 Wet Grinder. 49 lbs.



Figure 17. Model G7120.

Call 1-800-523-4777 To Order

H5891, H5892 Diamond Dressers

Industrial diamond for dressing grinding wheels. 8¼" long round body with knurled grip for maximum control. Includes protective rubber end cap.

Model H5891 ¼ Carat.

Model H5892 ¾ Carat.



Figure 18. Models H5891 & 5892.

H5944, H5945, H5946 Wheel Dressers

Exposes new grains for aggressive cutting on all types of grinding wheels. Star wheels and discs are hardened steel. Cast iron handle provides stabilizing mass for better control.

H5944 #0 Wheel Dresser.

H5945 #1 Wheel Dresser.

H5946 #2 Wheel Dresser.



Figure 19. Models H5944, H5945, H5946.

SECTION 6: MAINTENANCE

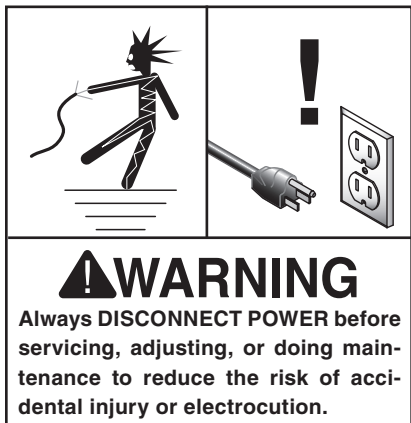

For optimum performance from your machine, routinely check the condition of the following items and repair or replace as necessary:

- Cracked or loose grinding wheel.
- Loose hardware.
- Bent universal support.
- Worn switch.
- Worn or damaged cords and plugs.
- Any other condition that could hamper the safe operation of this machine.

Grinding Wheels

The grinding wheel should be inspected before every use. Use the ring test method noted in **Wheel Inspection** on **Page 10** to verify the structural integrity. Take care in storing grinding wheels to keep them free from potential damage from moisture, by being dropped, or having other items drop on them.

Wheel Replacement

To replace the grinding or stropping wheel:

1. **DISCONNECT THE GRINDER FROM POWER!**
2. Hold the wheel from turning, and remove the arbor nut or knob which holds the wheel on.
3. Remove the outer washer and wheel.
4. Install the new wheel, then replace the washer and nut or knob.

Water Reservoir

Be sure to periodically empty, rinse and refill the water reservoir with clean water depending on frequency of use. Failing to do so can lead to a buildup of sediment on the wheel itself, reducing grinding performance.

SECTION 7: SERVICE

Troubleshooting

Motor and Electrical

Symptom	Possible Cause	Solution
Motor will not start; fuses or circuit breakers blow	<ol style="list-style-type: none">1. Disabling key is at fault.2. Open circuit in motor or loose connections.3. Start capacitor is at fault.4. Short circuit in motor or loose connections.5. Incorrect fuses or circuit breakers in power supply.	<ol style="list-style-type: none">1. Install/replace disabling key; replace switch.2. Inspect/repair all lead connections on motor for loose or open connections.3. Replace start capacitor.4. Inspect all connections on motor for loose or shorted terminals or worn insulation.5. Install correct fuses or circuit breakers.
Motor slows, stops, or will not start; fuses or circuit breakers blow.	<ol style="list-style-type: none">1. Motor overloaded.2. Short circuit in motor or loose connections.	<ol style="list-style-type: none">1. Reduce load on motor.2. Inspect connections on motor for loose or shorted terminals or worn insulation.

Grinder Operations

Symptom	Possible Cause	Solution
Lines on surface of workpiece.	<ol style="list-style-type: none"> 1. Impurity on wheel surface. 2. Workpiece not being held tightly. 	<ol style="list-style-type: none"> 1. Dress the grinding wheel. 2. Use a holding device to firmly retain the workpiece.
Wheel dulls quickly, grit falls off.	<ol style="list-style-type: none"> 1. Depth of cut too great. 2. Bad wheel dress. 3. Defective wheel bonding. 	<ol style="list-style-type: none"> 1. Decrease the pressure of the workpiece into wheel. 2. Dress the wheel. 3. Consult manufacturer of grinding wheel.
Wavy condition on surface of workpiece.	<ol style="list-style-type: none"> 1. Machine vibrating. 2. Workpiece is not held in place firmly. 3. Wheel face uneven. 	<ol style="list-style-type: none"> 1. Make sure machine is securely positioned on a level surface. 2. Use a holding device to firmly retain the workpiece. 3. Dress the grinding wheel.
Grinding wheel clogs.	<ol style="list-style-type: none"> 1. Bad wheel dress. 2. Wrong material is being ground. 3. Dirty water in reservoir. 	<ol style="list-style-type: none"> 1. Dress the wheel. 2. Grind ferrous metals only. 3. Drain and refill reservoir.
Excessive vibrations from machine.	<ol style="list-style-type: none"> 1. Bad wheel dress. 2. Wheel is water-logged. 3. Machine is positioned on uneven surface. 	<ol style="list-style-type: none"> 1. Dress the wheel. 2. Allow wheel to dry, then inspect wheel, replace if needed. 3. Reposition machine.
Stropping wheel loses performance.	<ol style="list-style-type: none"> 1. Insufficient wheel preparations. 2. Wheel is damaged. 	<ol style="list-style-type: none"> 1. Prepare wheel. 2. Replace wheel.

Wiring Diagram



View this page in color at www.grizzly.com.

⚠ DANGER
 Disconnect power before performing any electrical service. Electricity presents serious shock hazards that will result in severe personal injury and even death!

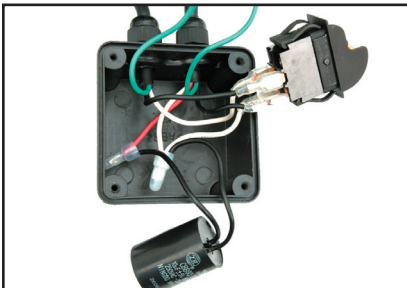
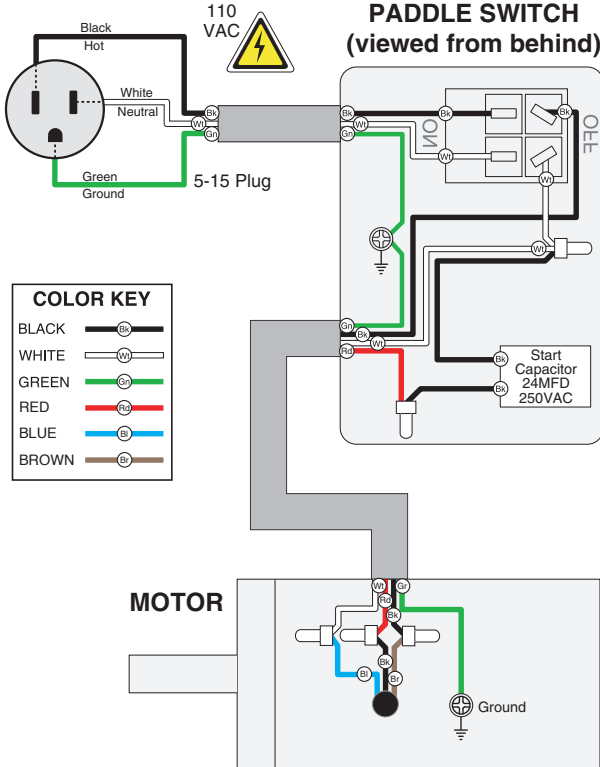

Figure 20. Switch connections.

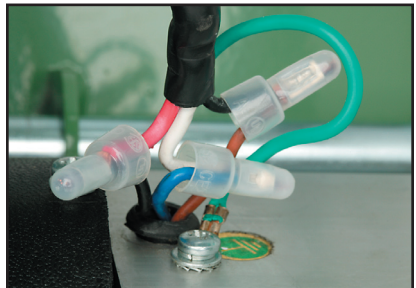
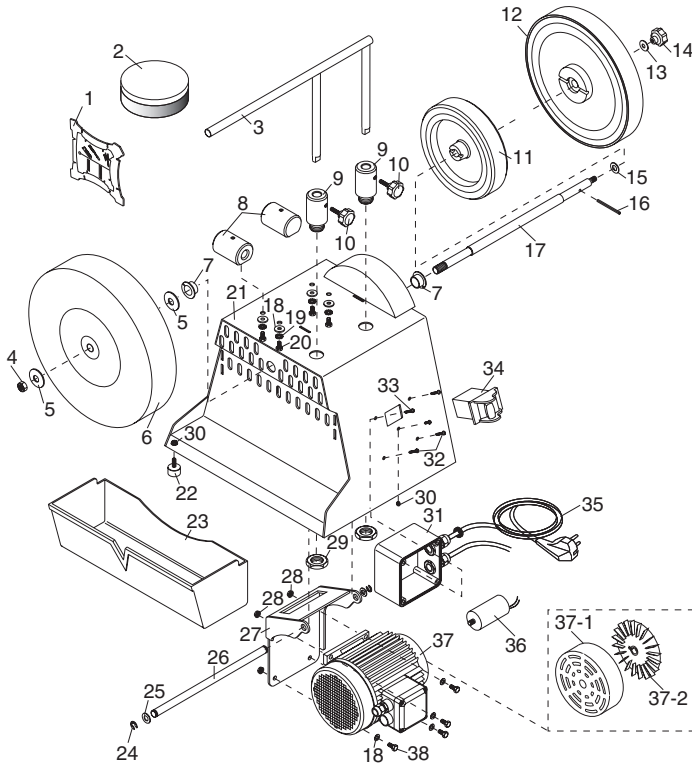

Figure 21. Motor connections.

Main Breakdown & Parts List



REF PART #	DESCRIPTION
1	PT10010001 ANGLE GUIDE
2	PT10010002 HONING PASTE
3	PT10010003 UNIVERSAL SUPPORT
4	PN09M HEX NUT M12-1.75
5	PW06M FLAT WASHER 12MM
6	PT10010006 GRINDING WHEEL
7	PT10010007 BUSHING 15MM ID/17MM OD
8	PT10010008 HORIZ. SUPPORT HOLDER
9	PT10010009 VERT. SUPPORT HOLDER
10	PT10010010 KNOB BOLT M6-1 X 16
11	PT10010011 DRIVE WHEEL
12	PT10010012 STROPPING WHEEL
13	PW01M FLAT WASHER 8MM
14	PT10010014 KNOB NUT M8-1.25
15	PW06M FLAT WASHER 12MM
16	PRP23M ROLL PIN 4 X 44
17	PT10010017 ARBOR SHAFT
18	PW03M FLAT WASHER 6MM
19	PTLW05M EXT TOOTH WASHER 6MM
20	PB04M HEX BOLT M6-1 X 10

REF PART #	DESCRIPTION
21	PT10010021 GRINDER CASE
22	PT10010022 FOOT
23	PT10010023 WATER RESERVOIR
24	PEC015M E-CLIP 8MM
25	PW04M FLAT WASHER 10MM
26	PT10010026 MOTOR BRACKET SHAFT
27	PT10010027 MOTOR BRACKET
28	PN01M HEX NUT M6-1
29	PT10010029 SPECIAL NUT
30	PN04M HEX NUT M4-.7
31	PT10010031 SWITCH HOUSING
32	PHTEK8M TAP SCREW M4 X 20
33	PS38M PHLP HD SCR M4-.7 X 10
34	PT10010034 SWITCH W/DISABLING KEY
35	PT10010035 POWER CORD
36	PT10010036 S CAP 10M 250V 1-3/16 X 1-5/8
37	PT10010037 MOTOR 1/4HP 110V 1650RPM
37-1	PT10010037-1 MOTOR FAN COVER
37-2	PT10010037-2 MOTOR FAN
38	PHTEK15M TAP SCREW M4 X 10

Warning Labels Breakdown & Parts List

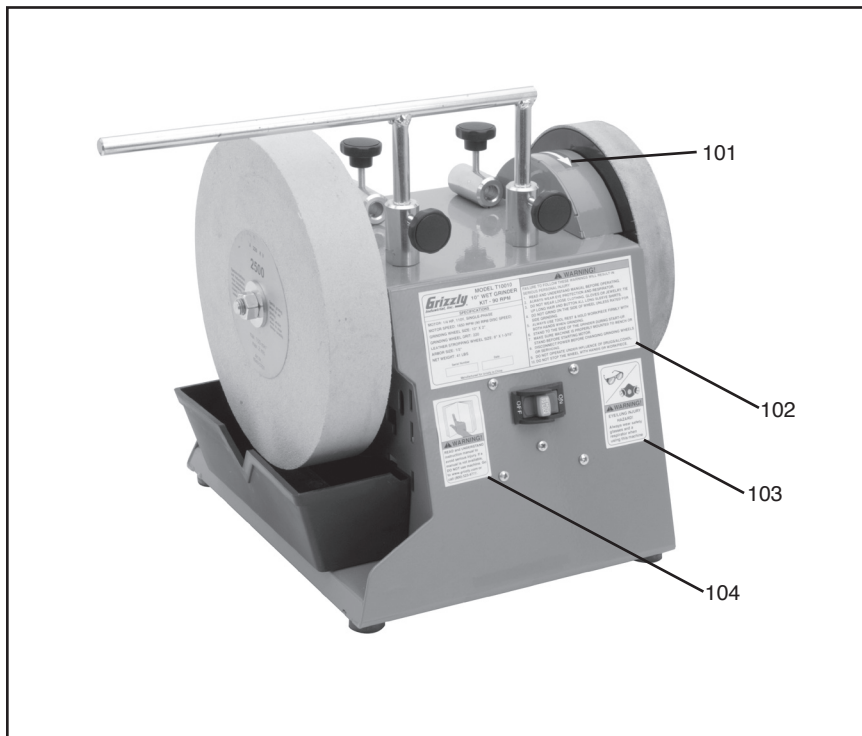

REF	PART #	DESCRIPTION
101	PT10010101	ROTATION DIRECTION ARROW
102	PT10010102	MACHINE ID LABEL

REF	PART #	DESCRIPTION
103	PT10010103	RESPIRATOR LABEL VERT
104	PLABEL-12A	READ MANUAL-VERTICAL NS 7/05



WARRANTY CARD

Name _____

Street _____

City _____ State _____ Zip _____

Phone # _____ Email _____ Invoice # _____

Model # _____ Order # _____ Serial # _____

*The following information is given on a voluntary basis. It will be used for marketing purposes to help us develop better products and services. **All information is strictly confidential.***

1. How did you learn about us?

Advertisement Friend Catalog
 Card Deck Website Other: _____

2. Which of the following magazines do you subscribe to?

Cabinet Maker Popular Mechanics Today's Homeowner
 Family Handyman Popular Science Wood
 Hand Loader Popular Woodworking Wooden Boat
 Handy Practical Homeowner Woodshop News
 Home Shop Machinist Precision Shooter Woodsmith
 Journal of Light Cont. Projects in Metal Woodwork
 Live Steam RC Modeler Woodworker West
 Model Airplane News Rifle Woodworker's Journal
 Modeltec Shop Notes Other:
 Old House Journal Shotgun News

3. What is your annual household income?

\$20,000-\$29,000 \$30,000-\$39,000 \$40,000-\$49,000
 \$50,000-\$59,000 \$60,000-\$69,000 \$70,000+

4. What is your age group?

20-29 30-39 40-49
 50-59 60-69 70+

5. How long have you been a woodworker/metalworker?

0-2 Years 2-8 Years 8-20 Years 20+ Years

6. How many of your machines or tools are Grizzly?

0-2 3-5 6-9 10+

7. Do you think your machine represents a good value? Yes No

8. Would you recommend Grizzly Industrial to a friend? Yes No

9. Would you allow us to use your name as a reference for our customers in your area?

Note: *We never use names more than 3 times.* Yes No

10. Comments: _____

Send a Grizzly Catalog to a friend:

Name _____
Street _____
City _____ State _____ Zip _____

FOLD ALONG DOTTED LINE

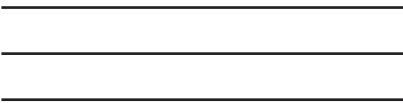

Place
Stamp
Here



GRIZZLY INDUSTRIAL, INC.
P.O. BOX 2069
BELLINGHAM, WA 98227-2069



TAPE ALONG EDGES--PLEASE DO NOT STAPLE

WARRANTY

Grizzly Industrial, Inc. warrants every product it sells for a period of **1 year** to the original purchaser from the date of purchase. This warranty does not apply to defects due directly or indirectly to misuse, abuse, negligence, accidents, repairs or alterations or lack of maintenance. This is Grizzly's sole written warranty and any and all warranties that may be implied by law, including any merchantability or fitness, for any particular purpose, are hereby limited to the duration of this written warranty. We do not warrant or represent that the merchandise complies with the provisions of any law or acts unless the manufacturer so warrants. In no event shall Grizzly's liability under this warranty exceed the purchase price paid for the product and any legal actions brought against Grizzly shall be tried in the State of Washington, County of Whatcom.

We shall in no event be liable for death, injuries to persons or property or for incidental, contingent, special, or consequential damages arising from the use of our products.

To take advantage of this warranty, contact us by mail or phone and give us all the details. We will then issue you a "Return Authorization Number," which must be clearly posted on the outside as well as the inside of the carton. We will not accept any item back without this number. Proof of purchase must accompany the merchandise.

The manufacturers reserve the right to change specifications at any time because they constantly strive to achieve better quality equipment. We make every effort to ensure that our products meet high quality and durability standards and we hope you never need to use this warranty.

Please feel free to write or call us if you have any questions about the machine or the manual.

Grizzly Industrial, Inc.
1203 Lycoming Mall Circle
Muncy, PA 17756
Phone: (570) 546-9663
Fax: (800) 438-5901

E-Mail:
techsupport@grizzly.com

Web Site: <http://www.grizzly.com>

Thank you again for your business and continued support. We hope to serve you again soon!

grizzly.com

TOOL WEBSITE

Buy Direct and Save with Grizzly® – Trusted, Proven and a Great Value!

*Visit Our Website Today And Discover
Why Grizzly® Is The Industry Leader!*

- SECURE ORDERING
- ORDERS SHIPPED WITHIN 24 HOURS
- E-MAIL RESPONSE WITHIN ONE HOUR

-OR-

Call Today For A **FREE**

Full Color Catalog

1-800-523-4777

